

# The Fox 700 series

**a limited production of  
high specification craft**

**700 Family Cruiser**

**700 Sports Fisherman**

**700 Super Weekender**

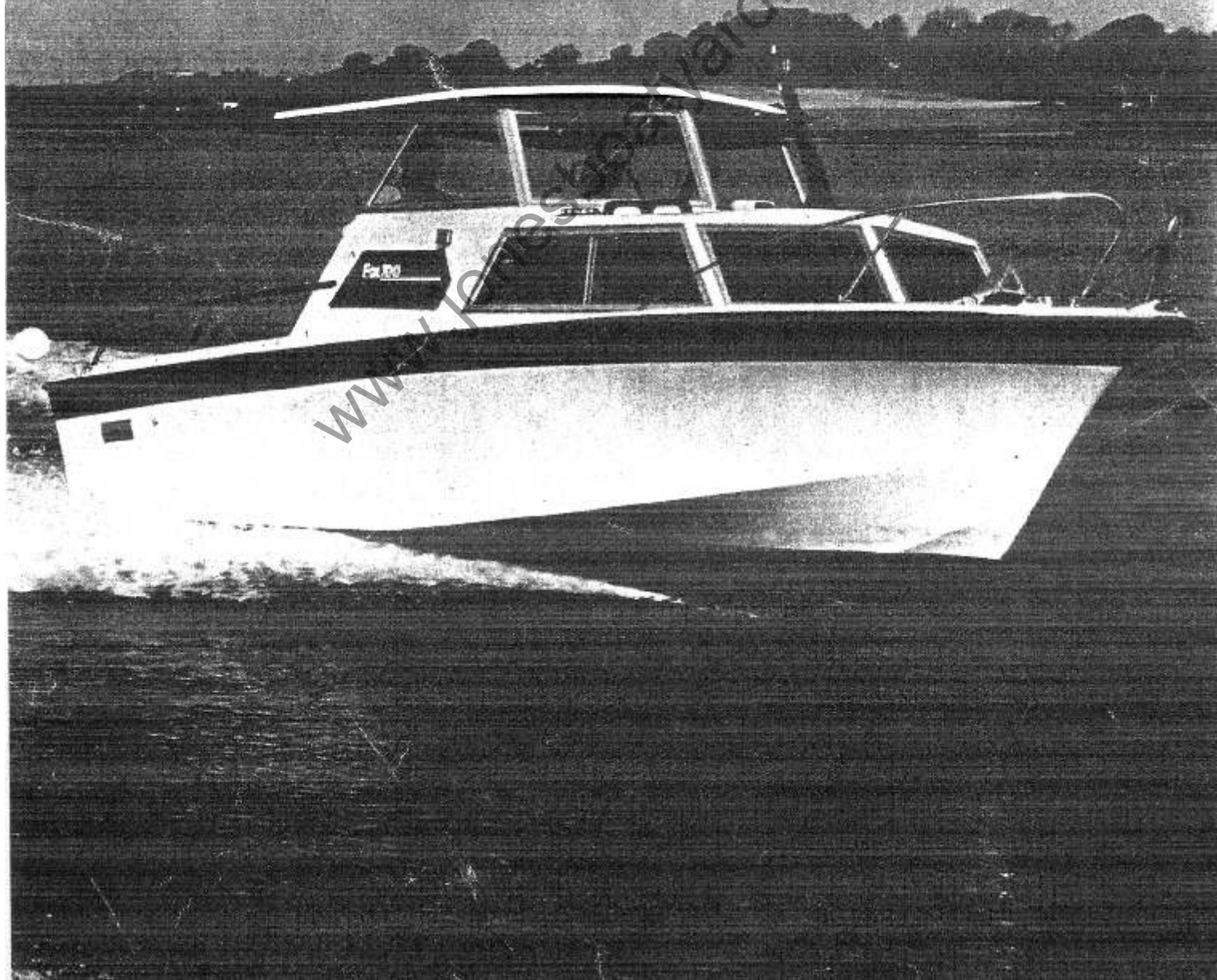

# The Super Weekender

## A sleek and beautiful power cruiser

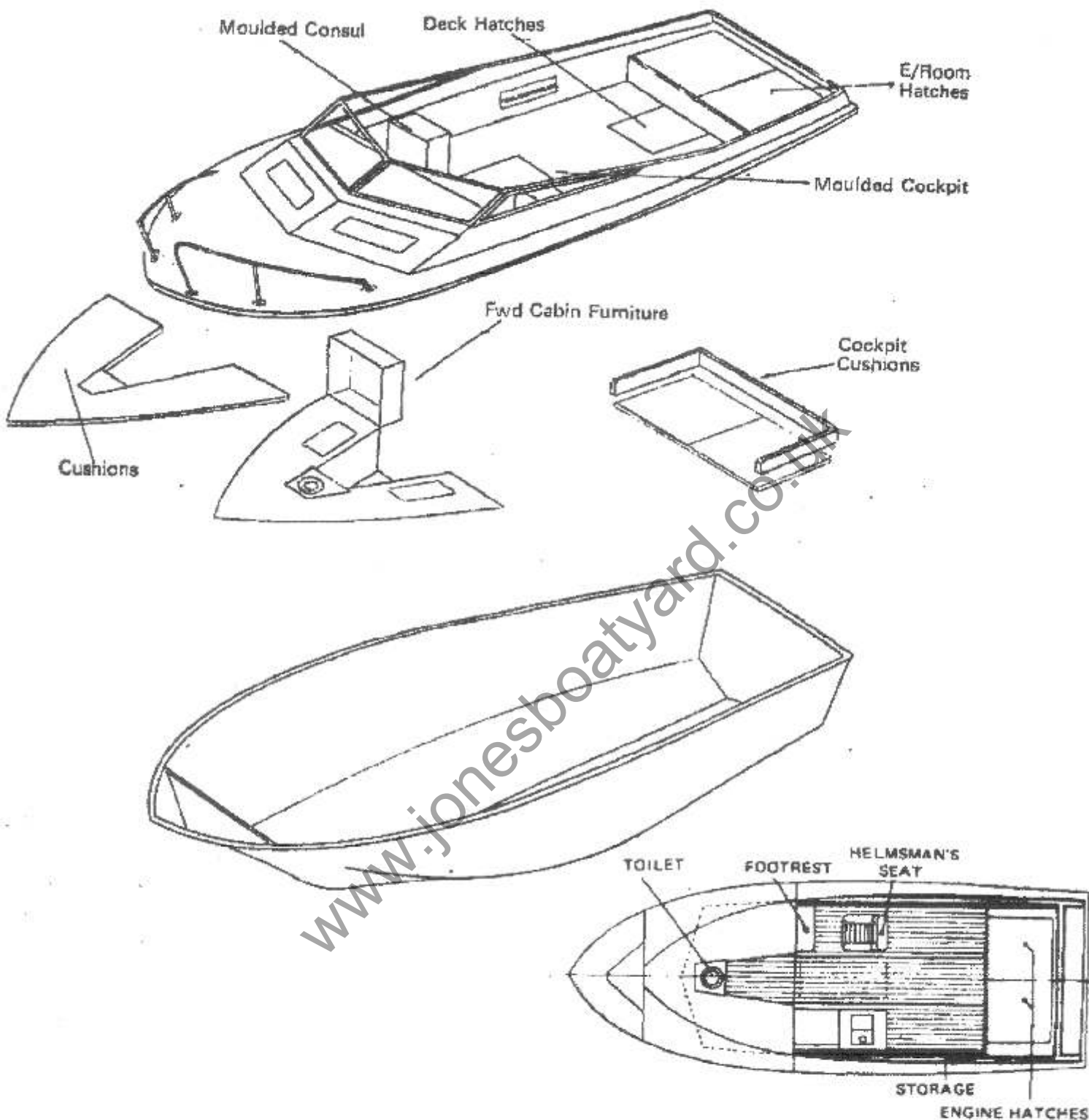

### FOX KITS

Fibreglass kits—Hulls, deck moulds and interiors all constructed of high quality G.R.P. to first class specifications.

The high speed, hard chine exceptionally seaworthy hull forms the basis of 3 well designed craft; a luxury 3/4 berth cruiser, a 2 berth large cockpit Sports or fishing boat, and a 2 berth fast power cruiser.

We reserve the right to change specification without notice.

Interior layouts can be adapted to your own choice. Hulls are capable of speeds up to 30 knots, and are capable of taking petrol or diesel engines, up to a maximum of 280 B.H.P.

By constructing from a quality kit, you will be amazed at the saving.

**C. H. Fox & Sons Ltd.**

*The Strand Wharstead*

*Ipswich England*

*Telephone Ipswich 62050*

# 2 berth sports or fishing cruiser with large cockpit

## SPECIFICATION

Overall length	22ft 9in	693.4cr
Beam	8ft 6in	259cm
Draft	1ft 4in	40.64cr
Overall height	8ft	243.8cr

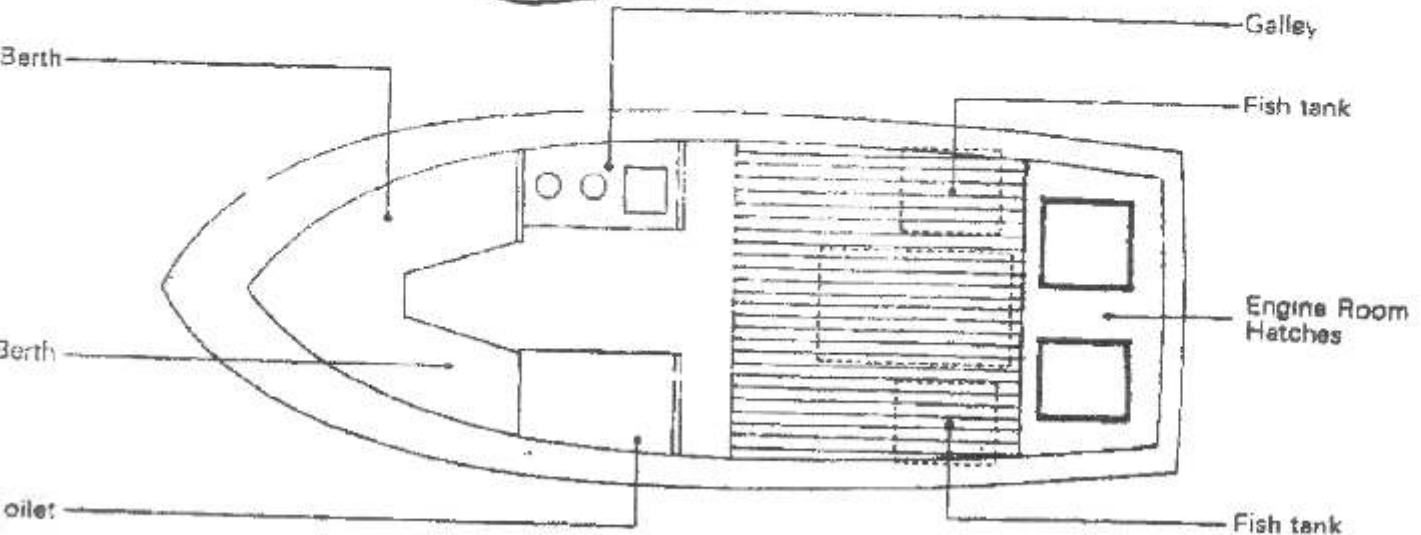
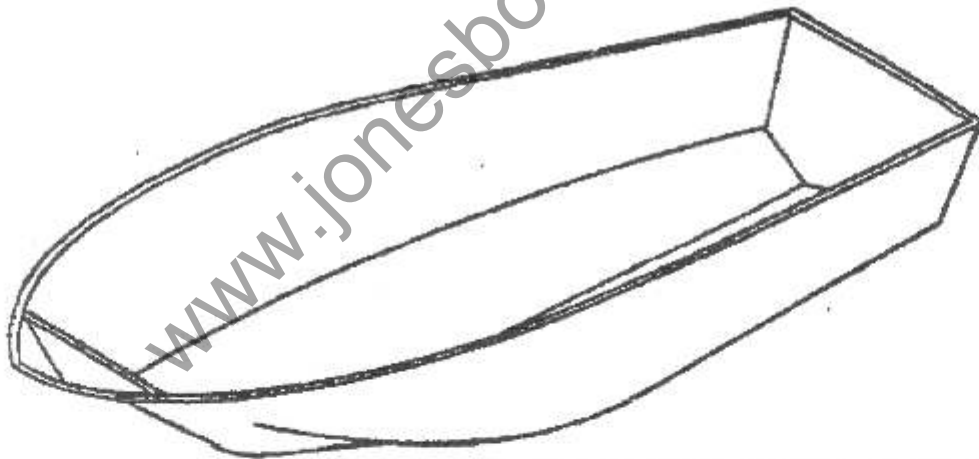
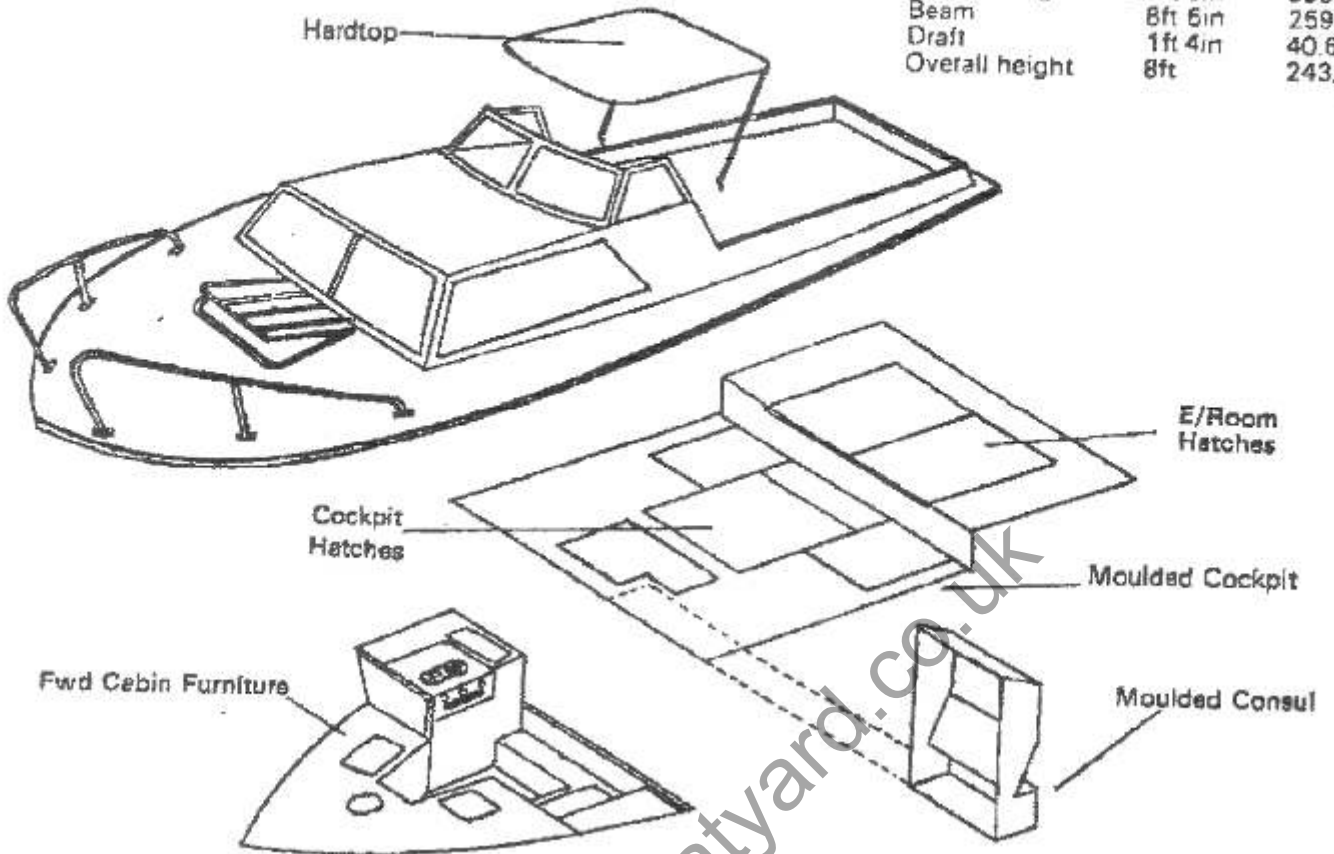

# 4 berth luxury family cruiser

## SPECIFICATION

Overall length	22ft 9in
Beam	8ft 6in
Draft	1ft 4in
Overall height	8ft

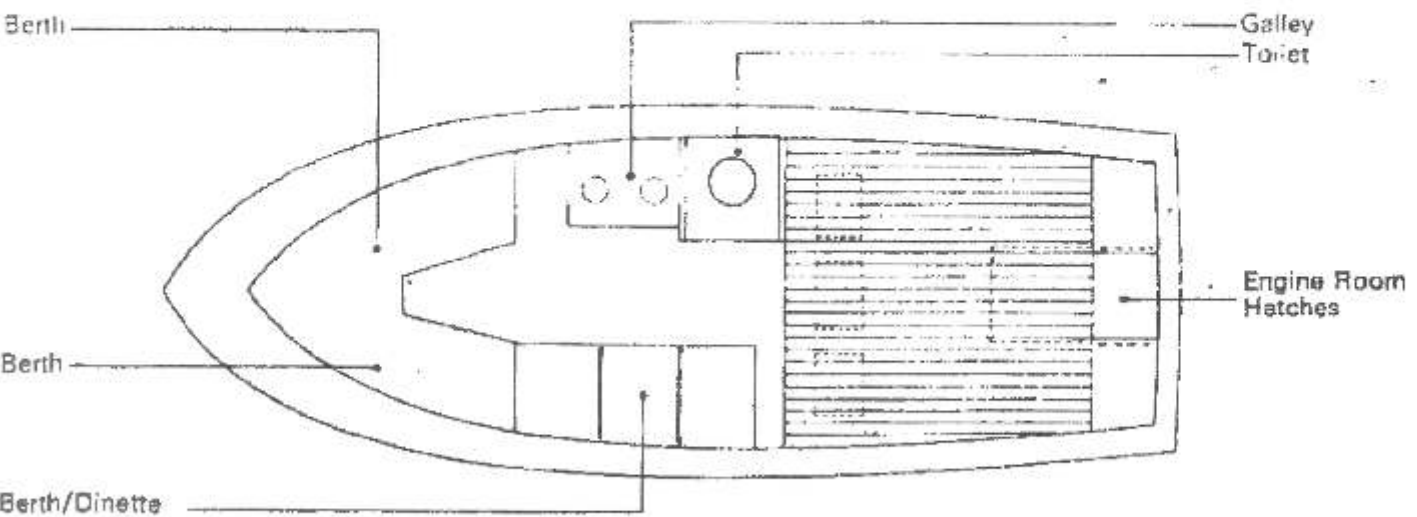
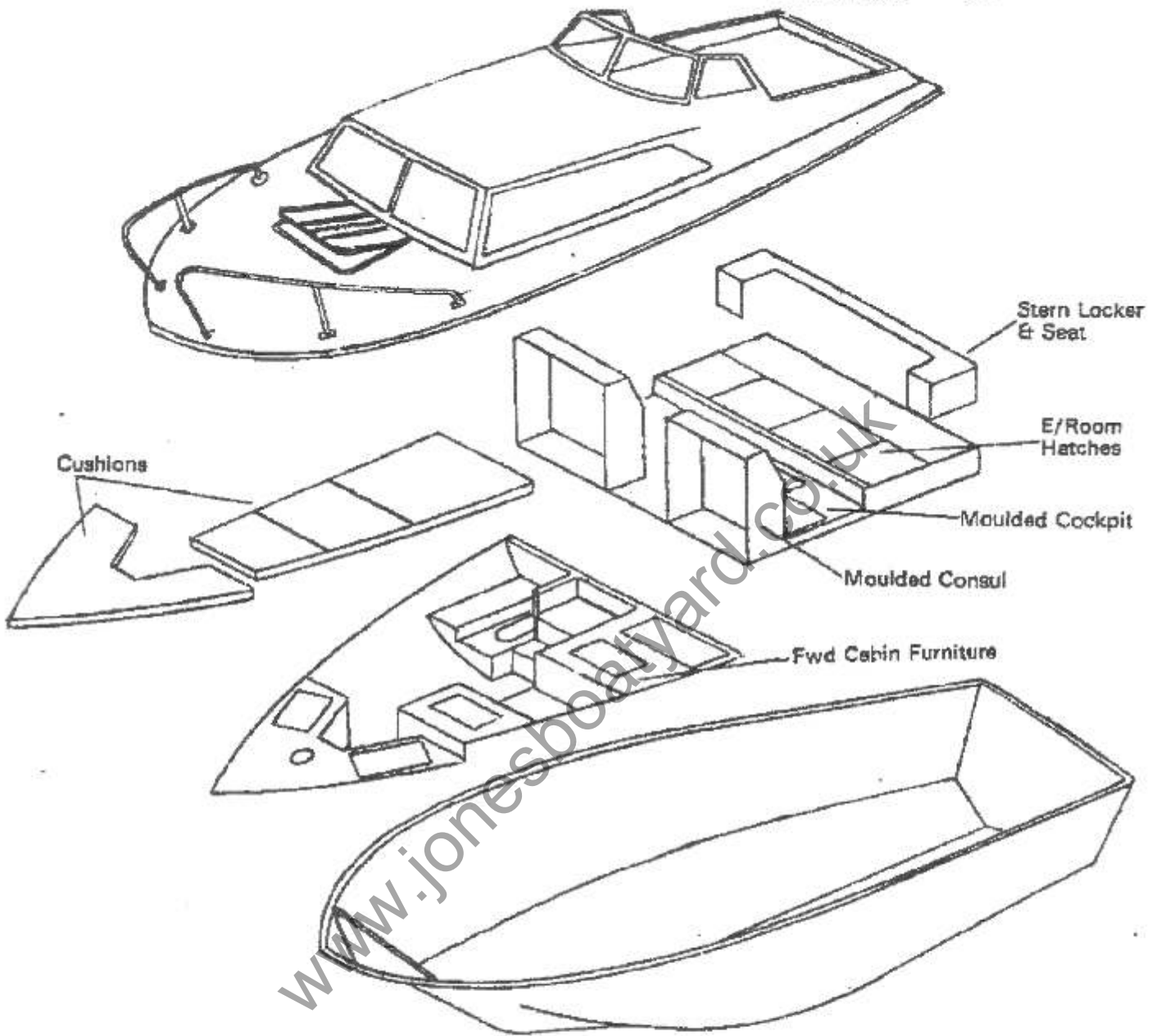

# IPSWICH MARINA LTD

TEL. IPSWICH (0473) 53850

## Fox Kits

### Specification

#### STAGE (1)

All 3 models hull and deck only. Hull stringers, deck with strengthening under fore and side decks.

#### STAGE (2)

##### Family Cruiser

Hull: With stringers.  
Deck: With sandwich strengthening to fore deck, side decks and cabin roof.  
Cockpit: including cabin bulkhead, moulded consul, with all stress points strengthened. (Bench Seat) in 2 parts.  
Aft Locker:  
Cockpit and Engine Room Hatches: 7 in total all strengthened with balsa, giving basic layout of interior, strengthened at stress points.  
Cabin Furniture: Moulding fits under cabin furniture.  
Water Tank: 2 in number and fit either side of cockpit.  
Flash Panels:

##### Sports Fishermen

Hull: as with Family Cruiser.  
Deck: as with Family Cruiser.  
Cockpit and Engine Room Hatches: 6 in total all strengthened with balsa. Separate moulding to be fixed to bulkhead when constructing.  
Consul: giving basic layout of interior strengthened at stress points.  
Cabin Furniture: single moulding.  
Hard Top: as with Family Cruiser.  
Water tank: as with Family Cruiser.  
Flash Panels:

##### Super Weekender

Hull: As with other 2 models  
Deck: incorporating, cockpit, cabin bulkhead and consul. With sandwiched strengthening as with other two models.  
Cabin Furniture: As with other two models.  
Water Tank: As with other two models.

#### STAGE (3)

All models as with stage 2 plus, (1) Hull and deck bonded together complete with quality aluminium and rubber fender, (2) Transom board bonded in, cockpit support bulkheads bonded in, hull and deck bonded together complete with fendering, furniture and cockpit located in position (not bonded).

Strengthening for all models is sandwiched between lay up's during moulding.

Standard colours are cream and brown, hull is cream with a 6" moulded in flash line from top of hull, flash panels and furniture brown, all other mouldings are cream.

# 700 Sports Fisherman

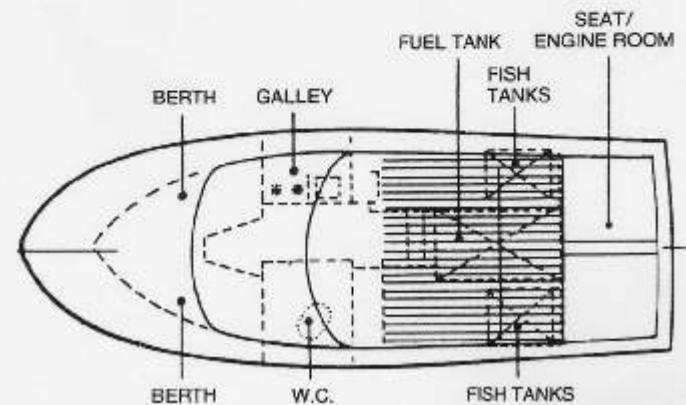
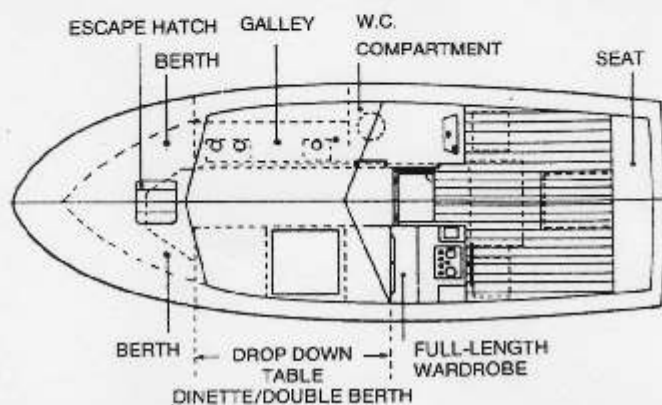
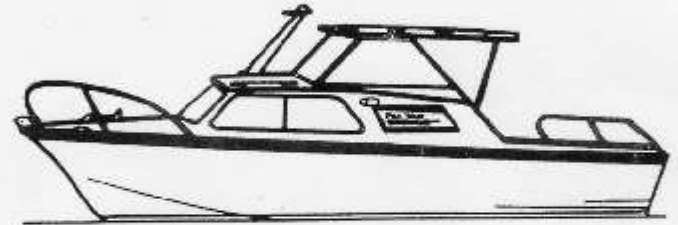
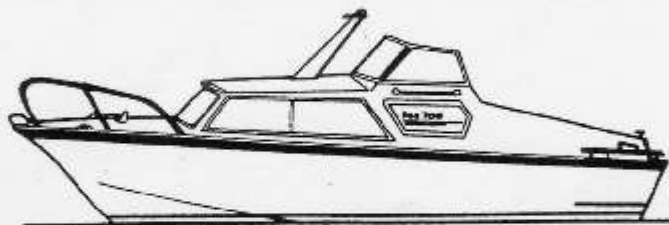
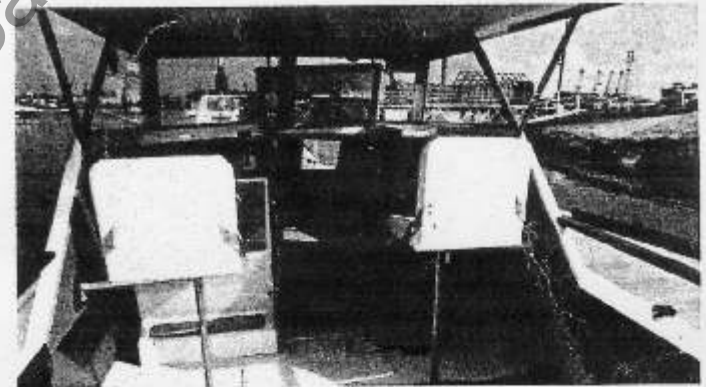
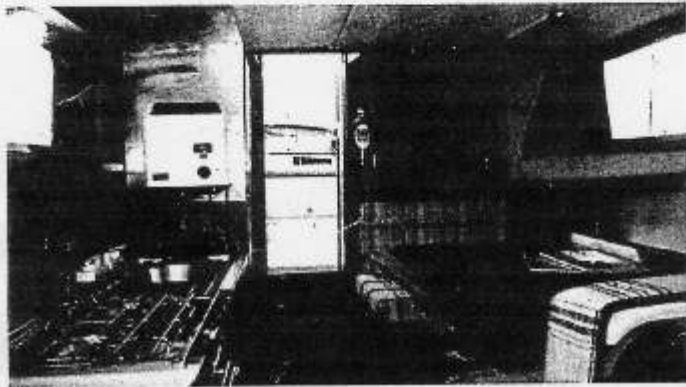

# Fox Kits

Family Cruiser  
Sports Fisherman  
Super Weekender

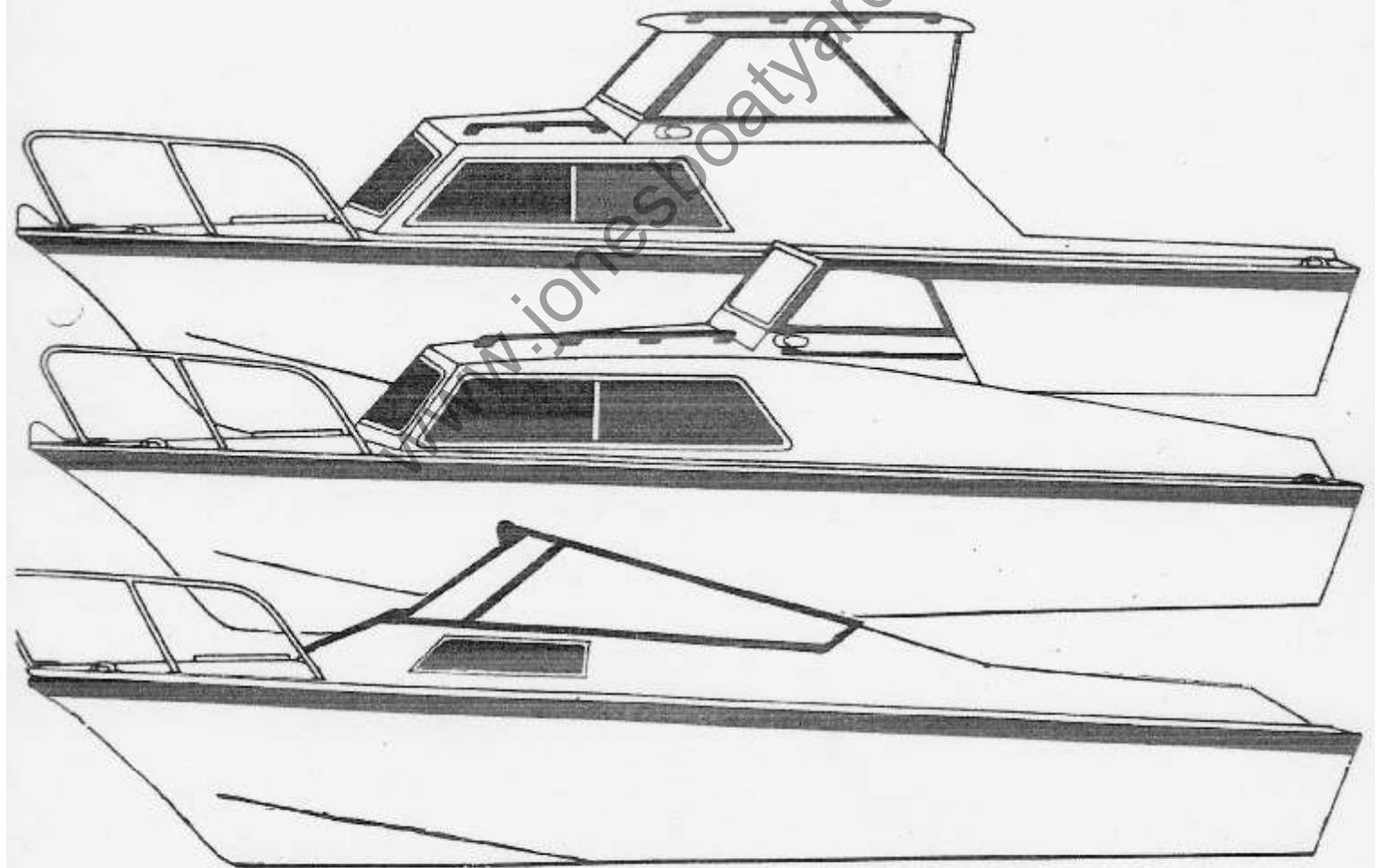

## Fox Kits

### SPECIFICATION

**Stage (1)** All 3 models hull and deck only. Hull stringers, deck with strengthening under fore and side decks.

**Stage (2)**

#### FAMILY CRUISER

Hull: with stringers.  
Deck: with sandwich strengthening to fore deck, side decks and cabin roof.  
Cockpit: including cabin bulkhead, moulded consul, with all stress points strengthened.  
Aft Locker: (Bench Seat) in 2 parts.  
Cockpit and Engine Room Hatches: 7 in total all strengthened with balsa.  
Cabin Furniture: giving basic layout of interior, strengthened at stress points.  
Water Tank: Moulding fits under cabin furniture.  
Flash Panels: 2 in number and fit either side of cockpit.

#### SPORTS FISHERMAN

Hull: as with Family Cruiser.  
Deck: " " " "  
Cockpit and Engine Room Hatches: 6 in total all strengthened with balsa.  
Consul: Separate moulding to be fixed to bulkhead when constructing.  
Cabin Furniture: giving basic layout of interior strengthened at stress points.  
Hard top: single moulding.  
Water tank: as with Family Cruiser.  
Flash Panels: " " " "

#### SUPER WEEKENDER

Hull: as with other 2 models.  
Deck: incorporating, cockpit, cabin bulkhead and consul. With sandwiched strengthening as with other two models.  
Cabin Furniture: As with other two models.  
Water Tank: " " " "

**Stage (3)**

All models as with stage 2 plus, (1) Hull and deck bonded together complete with quality aluminium and rubber fender, (2) Transom board bonded in, cockpit support bulkheads bonded in, hull and deck bonded together complete with fendering, furniture and cockpit located in position (not bonded).

Strengthening for all models is sandwiched between lay up's during moulding.

Standard colours are cream and brown, hull is cream with a 6" moulded in flash line from top of hull, flash panels and furniture brown, all other mouldings are cream.



FOX 700 SHOW BOAT EXTAS;

1. Supply and fit windows/screens/hardtop supports etc.

	£	Labour	£
Teak =	16.00		£ 60.00
Sealant =	4.90		
Screws =	5.00		
R/T supports	14.50		
Windows etc	445.00		
" inserts	12.00		
Total;	<u>481.50</u>		<u>£481.40</u>
		Total;	<u>£561.40</u>

2. Main Bulkheads;

	£	Labour	£
Plywood (teak faced)	40.25		£ 44.00
Glass materials	2.00		
Screws	<u>1.00</u>		
Total;	<u>43.25</u>	Total;	<u>£ 43.25</u>
			<u>£ 87.25</u>

3. Supply and Fit Mast;

Labour	£ 4.00
Materials	<u>£ 35.00</u>
Total;	<u>£ 39.00</u>

4. Supply and fit deck fittings;

	£	Labour	£
Bow roller	21.45		£ 20.00
Fairleads	3.14		
Foredeck bollard	6.34		
Aft bollard	10.02		
Fender eyes	2.00		
Hatch rings	8.00		
Bolts/screws	5.00		
Sealants	<u>2.45</u>		
Total;	<u>58.40</u>	Total;	<u>£ 58.40</u>
			<u>£ 78.40</u>

FOX 700 SERIES KLT BOATS.

RETAIL PRICE LIST @ MARCH 1981;

<u>FAMILY CRUISER:</u>	<u>£</u>	<u>SPORTS FISHERMAN:</u>	<u>£</u>	<u>SUPERWEEKENDER:</u>	<u>£</u>
STAGE 1	2,385	2,265		2,385	
STAGE 2	3,020	2,900		2,770	
STAGE 3	3,620	3,490		3,360	

Stage 1 = Hull and deck only,

Stage 2 = Hull, deck, cockpit, hatches and furniture mouldings,

Stage 3 = As per 1 and 2, plus bulkheads under cockpit, transom board, bonded. Hull and deck bonded with fendering, cockpit and cabin furniture located into position.

**HARDTOP:** For Family Cruiser = £198 extra.

The above prices are ex works, ex VAT @ current rate.

They are subject to change without notice.

We are able to give substantial discounts on most makes of engine to fit these craft.

www.kitesportyard.co.uk

# 700 Super Weekender

The Super Weekender is the youngest in the 700 range. Her style and design make her a luxurious sleek and beautiful power cruiser. Her lines and low profile enable her to attain speeds well in excess of 30 knots if required. She offers 2 berth accommodation in the forecabin plus this spacious comfortable cockpit.

This craft is designed for speed and excitement but maintains her safe sea keeping qualities.

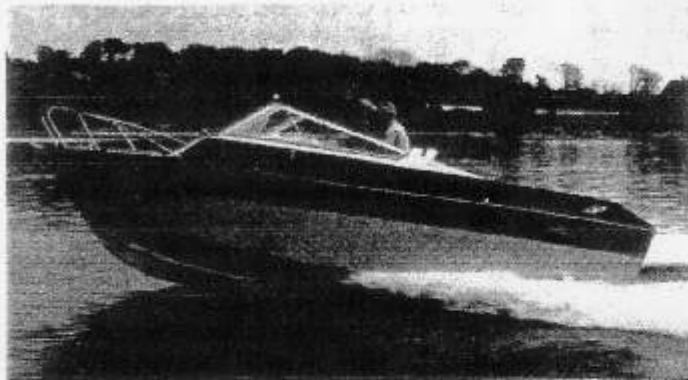

## Cabin

The fully upholstered cabin offers two full-size single berths and between them is the cleverly concealed toilet. A small 2 burner spirit cooker is recessed in the starboard bulkhead housed in an insulated alcove. There is ample ventilation by way of tannoy vents and escape hatch. Stowage is beneath the bunks.

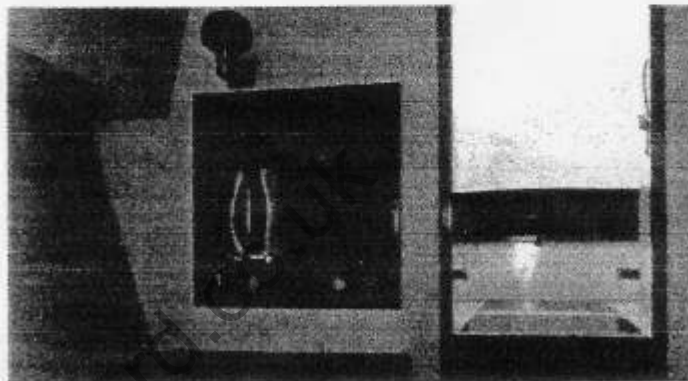

## Cockpit

Here as with the other two models the large G.R.P. self-draining cockpit needs little maintenance. It can accommodate 4-6 people in comfort. The fully upholstered stern seat can if required be used as another double berth when the canopy is erected. There are large storage lockers under the seats plus ample stowage beneath the cockpit floor. The moulded console accommodates all the necessary engine controls and instruments.

## Engine Room

The engine compartment is large enough to fit up to twin 15 h.p. petrol engines and has the same safety features as the two sister ships.

## Deck Fittings

All of stainless steel or quality anodised aluminium.

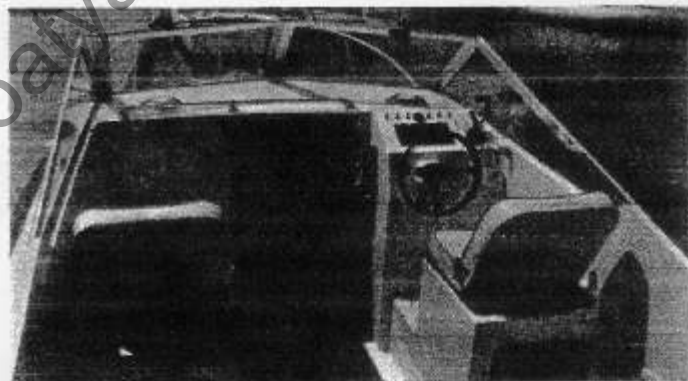

Specification is subject to change without notice.

## Standard Equipment

Two upholstered berths in forecabin  
Deck head with panelled upholstery  
Chemical toilet in forecabin  
Two burner cooker in forecabin  
Upholstered stern sunseat  
Helmsman and navigator's seats  
Stainless steel pulpit  
Stainless steel sink in cockpit  
Pressurised fresh water supply  
All round cockpit grab rail  
Escape hatch in foredeck  
D.O.T.I. approved navigation lights  
Extractor fan in engine room  
Auto-fire extinguisher in engine room and tank space  
Manual fire extinguisher in cabin  
Electric bilge pump  
Windscreen wiper  
Horn

Quality anodised aluminium framed windows in toughened glass  
15 lb C.Q.R. anchor with warp and chain  
Cockpit canopy and frame

**Engines** - For this model we recommend the Volvo Penta range of Marine petrol or diesel engines

## Specification

Overall length - 693.4cm (22' 9")  
Beam - 259cm (8' 6")  
Draft - 83.8cm (2' 9")  
Overall height - 213.4cm (7' 0")  
with hood 248.9cm (8' 2")  
Speeds up to 56 k.p.h. (35 m.p.h.) according to engine.

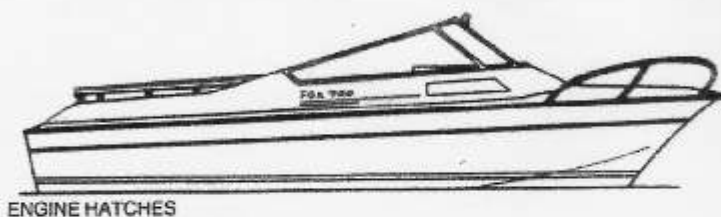

ENGINE HATCHES

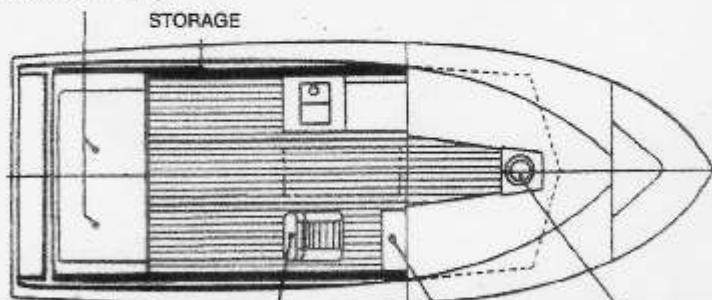

STORAGE  
HELMSMAN'S SEAT FOOTREST MARINE TOILET

**FOX OF**

**C.H. FOX & SON LTD.**

HALLEY BOAT YARD, WHEBSTEAD ROAD, IPSWICH IP2 8LJ

# 700 Sports Fisherman

The Sports Fisherman is built for your practical pleasure and designed for performance, rough weather handling and stability. A huge self draining cockpit with fish or equipment storage space, well raked vee'd toughened glass windscreen and a weatherwise streamlined hardtop to protect the helmsman and crew. Although she is basically a 2 berth Sports/Fishing cruiser she can accommodate four by utilising the large upholstered cockpit seat. She is obviously fitted out to the same high standards as her sister the Family Cruiser and has the same proven sea keeping qualities. It was in fact a 700 Sports Fisherman which in 1970 won the German Motor Yacht Association's Competition for the 'Long Voyage Challenge Trophy' with a cruise from Burnham-on-Crouch to the Swedish/Finnish border and via Helsinki to its home port of Heiligenhafen. The owner Manfred Hurkens says of his 23 foot Fisherman, "A very fine seaworthy boat, which I would take anywhere." The voyage covered some 3,804 sea miles and lasted 30 days.

## Cabin

with the family cruiser bulkheads etc., are in teak trim but for practical purposes the galley unit is a G.R.P. moulding. The unit houses a 2 burner cooker and grill and stainless steel sink with cold water supply. There is storage space in the galley unit and under the bunks. The two single berths can easily be made a double by lowering the table and using a bunk infill cushion. The toilet compartment is larger than normal for this size of craft and is fitted with a chemical toilet, wash basin with a cold water supply and a mirror.

## Cockpit

The large self-draining G.R.P. cockpit is the main attraction on this model and can be fitted with either single engine cover or large twin engine compartment. There is ample space for six persons with either their fishing or water sports equipment. The cockpit sides can be finished with upholstered panels as standard, or for a more hard wearing finish for little extra cost, teak battens or marine ply cockpit lockers. Underneath the cockpit are two watertight storage compartments and vast area for general equipment.

## Engine Room

As with the Family Cruiser the engine compartment is large enough to hold twin 170 h.p. petrol engines, or the option most popular to Fisherman is the single engine cover which can be utilised as a seat. The engine room and tank space are vented and fitted with automatic fire extinguishers.

## Deck Fittings

All stainless steel or high quality anodised aluminium.

Specification is subject to change without notice.

## Standard Equipment

Two upholstered berths in fully carpeted forecabin  
 Upholstered stern sunseat  
 Upholstered panel headlining  
 Side fixing helmsman's seat  
 Stainless steel sink  
 2 Burner cooker with grill  
 Pressurised cold water supply supply  
 Stainless steel pulpit  
 Escape hatch in forecabin  
 D.O.T.I. approved navigation lights  
 Extractor fan in engine room  
 Auto-fire extinguishers in engine room and tank space  
 Manual fire extinguishers in galley  
 Electric bilge pump  
 Chemical toilet  
 Windscreen wiper

Horn  
 Anodised aluminium framed windows in toughened glass, side cabin windows sliding  
 15 lb C.Q.R. anchor with warp and chain  
 Cockpit canopy

**Engines** - Volvo Penta or C/T Marine petrol or diesel engines recommended

## Specification

Overall length - 693.4cm (22' 9")  
 Beam - 259cm (8' 6")  
 Draft - 83.8cm (2' 9")  
 Overall height - 259cm (8' 6")  
 Speeds up to 48 k.p.h. (30 m.p.h.) according to engine.

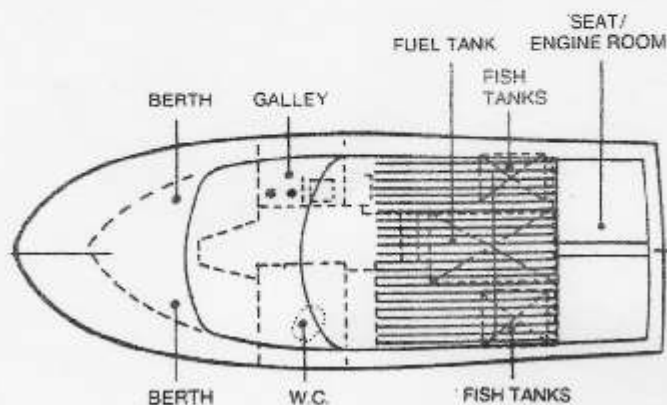
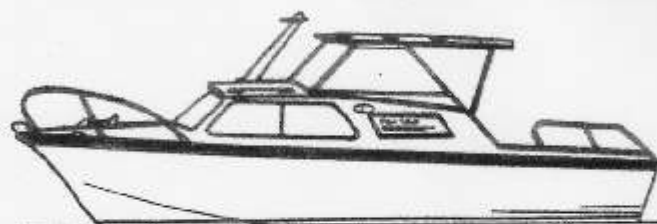

# 700 Family Cruiser

What do you expect from a 23 foot power cruiser? Step aboard the 700 Family Cruiser and have a pleasant surprise. Careful design and styling has made this beautiful and spacious craft comfortable for family use both at sea and in sheltered waters. C. H. Fox & Son Ltd., an old established boat building company with a long standing reputation for quality have combined their expertise with a well proven hull to produce what we feel is a high quality small cruiser for the owner seeking a boat built to standards not down to a price. On stepping on board you will sense she is built with care. Because the 700's are not mass produced, the owner's choice of upholstery patterns, interior trim and hull colours can be accommodated.



## Cabin

The fully upholstered cabin offers a luxury teak trim, 4 berths, ample storage space, long hanging locker and a 4 seater dinette unit. Any female crew member would be proud of the teak trimmed galley unit which comprises of a combined sink and cooker in stainless steel, oven, cold water supply and formica work surface.

## Toilet Compartment

All 700's are fitted with a chemical toilet as standard and on the aft bulkhead is the vanity unit and sink with cold water supply, also on the bulkhead is a sensible size mirror.

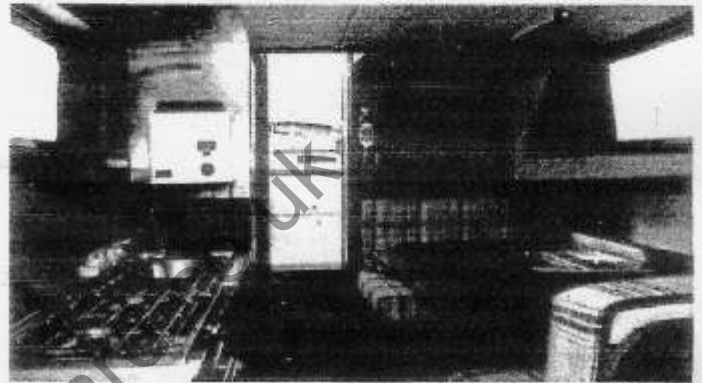

## Cockpit

The G.R.P. cockpit needs little maintenance and is moulded in the same colours as the hull. There is ample seating for 4-5 persons. The moulded console houses all the necessary engine controls and instruments. The helmsman has good all round vision and will find with the large destroyer type wheel and single lever engine controls, the handling is both smooth and positive.

## Engine Room

The engine compartment is large enough to install up to twin 170 h.p. engines, both this compartment and the tank space are vented and fitted with automatic fire extinguishers.

## Deck Fittings

All deck fittings are either of stainless steel or the best quality anodised aluminium.



Specification is subject to change without notice.

## Standard Equipment

Four Berths  
Separate toilet compartment with hand basin, vanity unit and mirror  
Fully upholstered berths, carpet and headlinings  
Hanging locker  
Galley with stainless steel sink, pressurised water supply, cooker with grill and oven  
Helmsman's seat  
Walkthrough pulpit  
Foredeck escape hatch  
Teak Taff rail  
D.O.T.I. approved navigation lights  
Extractor fan in engine room  
Auto-fire extinguishers in engine room and tank space  
Manual fire extinguisher in galley  
Electric bilge pump  
Windscreen wiper  
Horn

Anodised aluminium framed toughened glass windows (cabin windows sliding)  
15 lb C.Q.R. anchor with chain and warp  
Cockpit canopy with frame

**Engines** - Volvo Penta or C/T Marine petrol or diesel engines are recommended

## Specification

Overall length - 693.4cm (22' 9")  
Beam - 259cm (8' 6")  
Draft - 83.8cm (2' 9")  
Overall height - 243cm (8' 0")  
Speeds up to 48 k.p.h. (30 m.p.h.) according to engine.

