

CLEOPATRA programme





CLEOPATRA PROGRAMME 700 and 850 series

The internationally famous Cleopatra Programme. Presenting the 700 and 850 Series. Six fabulous models to choose from with a price to suit every pocket and a model for every requirement. You can go cruising in a quiet river or estuary or really go to sea with confidence in the well-designed, tough, seaworthy hulls. Safety, good design and luxury are the keynotes of the Cleopatra Programme. For simplicity of design, production continuity and economy, 700 and 850 Series are based on two first-class hull designs, a 23 ft for the 700 and a 28 ft hull for the 850 Range. There is a twofold advantage in using one standard hull for each of the series. First, production efficiency and economy results in cost savings. These are reflected in the competitive

prices of the Cleopatra Programme. Second and most important, two standard hulls are constantly undergoing tests with three different interiors and superstructures. With Essex Yacht Builders' policy of continuous improvement the buyer is always assured of the latest innovations in safety, good design and new materials.

A host of improvements are included in the current 700 and 850 Range of powerboats. With an even shorter extras list than ever before. New cockpit layouts with improved draining, bigger bilge pumps, improved fittings and more stainless steel to cut maintenance to the minimum with the accent on easy-clean laminate surfaces.

Sparkling white gelcoat on precision laid-up GRP specially designed new window frame units for greater strength and watertight qualities. Colour-keyed flash panels with matching flash lines, boot top, cockpit upholstery and trim. For greater hull protection new improved rubber rubbing strake. Turn these pages and see just what you've been missing!

Essex Yacht Builders Ltd.
Wallasea Island, Nr. Rochford, Essex, England
Telephone Canewdon 531/5 (STD) 03-706 531/5

Essex Yacht Builders Limited reserve the right to change specifications and prices without notice



*Front Cover: 700 Super Weekender at Speed
Back Cover: Wallasea Island, Essex, home of Cleopatra
Left: Sandstone relief of Cleopatra VII
Right: 850 International at Speed*



www.jonesboatyard.co.uk

700 SUPER WEEKENDER

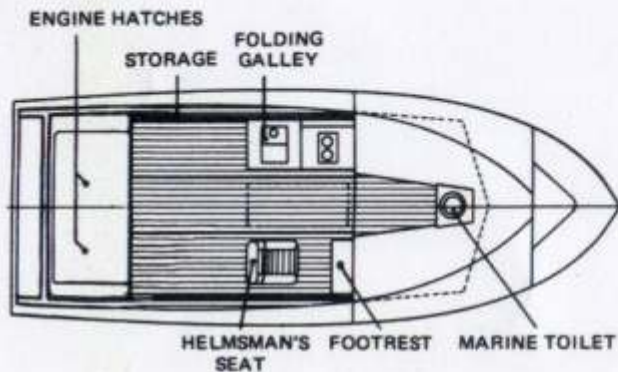
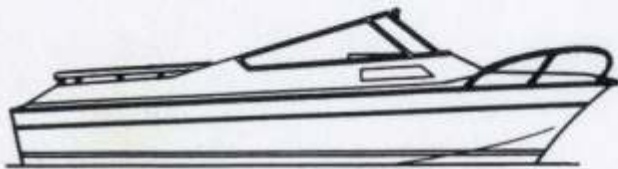

A design for excitement, a sleek and beautiful powerboat built just for your pleasure. Styled by Swedish marine designer Pelle Petterson.

Settle down in the deep upholstered helmsman seat, leave the weekend traffic behind and 'take off' in your Super Weekender. Silky smooth Morse controls, a leather-covered Sports steering wheel and luxury instrument panel. A brand-new moulded cockpit to stroll or lounge in and bigger than ever stern seat.

Open up the throttles, leave your week's cares behind and feel the response of that positive steering. Glance over your shoulder at the creamy wake astern, as you lift on the plane and feel the thrill of getting away. No need for you to look for an hotel at the day's end, because the Super Weekender has two full-sized berths in that roomy forecabin, together with a full-sized sea toilet.

With the canopy erected, on a warm summer night, there is the thrill of camp-style cooking on a miniature gas stove but with the luxury of washing up in the fitted stainless steel sink unit.

Just think of those sunny carefree days with a more luxurious than ever 700 Super Weekender.

Specification

Overall length 693.4 cm (22' 9")

Beam 259 cm (8' 6")

Draft 83.8 cm (2' 9")

Overall height 213.4 cm (7') with hood 228.9 cm (8' 2")

Weight 1,852 kg—1,966 kg (4,090 lb—4,340 lb)

Fuel capacity approx. 209 litres (47 gal.)

Speeds up to 56 KMPH (35 MPH) according to engine installations.

The Super Weekender is GRP moulded, with a specially constructed stiffened, high-speed hull.

Standard Equipment

Two upholstered berths in forecabin.

Sea toilet in forecabin.

Stern sunseat fully upholstered.

Upholstered helmsman and navigator's seats.

Stainless steel sink and portable gas stove.

Safe styled step-aboard pulpit.

Rubber rubbing strake round hull.

Round cockpit grab rail.

Escape hatch in foredeck.

Stem head fitting, mooring bollards and cleats.

Full navigation lights.

Fluorescent cabin lighting.

Engine room extractor fan, spark protected.

Electric bilge pump.

Teleflex Morse steering and Morse engine controls.

Antifouling treatment to hull.

Engines

A comprehensive range of Volvo Penta, high-performance engines—115/100, 130/270, 170/270 and AQd21/270 Volvo Penta diesel.

Top right: 700 Super Weekender

Bottom right: View of Cockpit

Far right: 700 Super Weekender at Speed





www.jonesboatyard.co.uk

700 SPORTS FISHERMAN

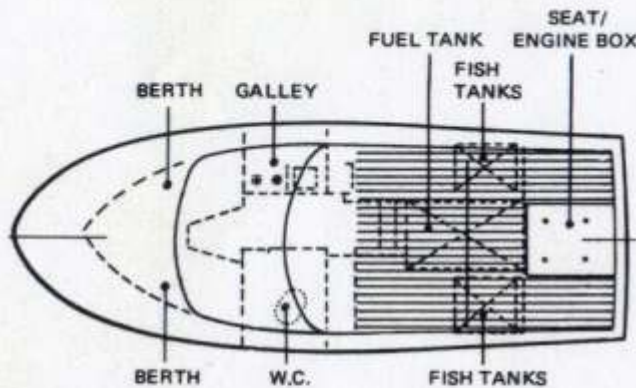
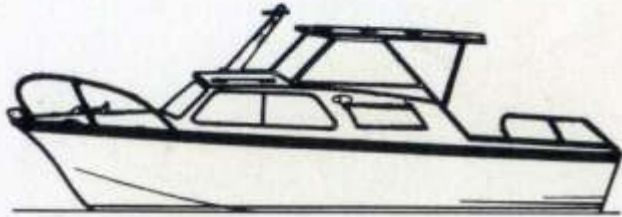

Built for your practical pleasure, and designed for performance, rough weather handling and stability. A huge self-draining cockpit with removable, flush-fitting fish boxes, well-raked veed safety glass wind-screen with special new window frames for added strength and reliability, and a weatherwise streamlined hardtop to protect helmsman and crew. A well-positioned, deep upholstered helmsman seat, big chromed steering wheel and positive Teleflex Morse steering. Single lever Morse engine controls, easy-to-reach instruments on moulded console with colour-matched upholstered side panels. A stainless steel taffrail, design matched to the step-aboard pulpit, completes the cockpit layout. Cabin access is by double doors headed by a perspex hatch. The GRP moulded interior has two deep upholstered full-sized berths, a compact galley unit with stainless steel sink and two-burner cooker and grill. An attractive toilet compartment is fitted with a hand basin, vanity unit and full-sized sea toilet. Sliding windows and forward escape hatch give ample ventilation to the interior of this exciting Sports Cruiser.

Specification

Overall length 693.4 cm (22' 9")
 Beam 259 cm (8' 6")
 Draft 83.8 cm (2' 9")
 Fuel capacity approx. 209 litres (46 gal.)
 Water capacity approx. 90 litres (20 gal.)
 Approx. range 25 hrs
 Diesel 402-482 km (250-300 miles)
 Petrol 240 km (150 miles)
 Weight from 1,859 kg (4,100 lb)
 Overall height 25.9 cm (8' 6")
 Speeds up to 48 KMPH (30 MPH) according to engine installation.

Standard Equipment

Two upholstered berths in fully carpeted forecabin.
 Separate toilet compartment, with hand basin, mirror and freshwater pump.
 Fully upholstered stern seat.
 Side-fixing helmsman seat, fully upholstered.
 Stainless steel sink with freshwater and storage compartment below.
 Two-burner cooker and grill.
 Safety-styled step-aboard pulpit and cockpit stern rail.
 All-round rubber rubbing strake.
 Safety escape hatch in foredeck.
 Stemhead fitting and foredeck fairleads.
 Centre mooring bolder on foredeck.
 Stern quarter mooring bollards.
 Jackstaff and socket.
 Removable mast with waterproof socket.
 Full navigation lights.
 Hawse pipe, anchor chocks, anchor chain and warps.
 Self-draining cockpit.
 Fish storage tanks.
 Sliding cabin windows.
 Color gas compartment piping and regulator.
 Engine room extractor fan, spark protected.
 Electric bilge pump.
 Electric horn, fuel gauge.
 Fluorescent cabin lighting.
 Morse engine controls, Teleflex/Morse steering.
 Heavy-duty 12v battery.
 Antifoul treatment to hull.

Engines

A comprehensive range of Volvo Penta, high-performance engines—115/100, 130/270, 170/270, AQd21/270 Volvo Penta diesel.

*Top right and Centre: Cockpit Detail
 Bottom right: 700 Sports Fisherman
 Far right: Fisherman at Speed*



700 FAMILY CRUISER

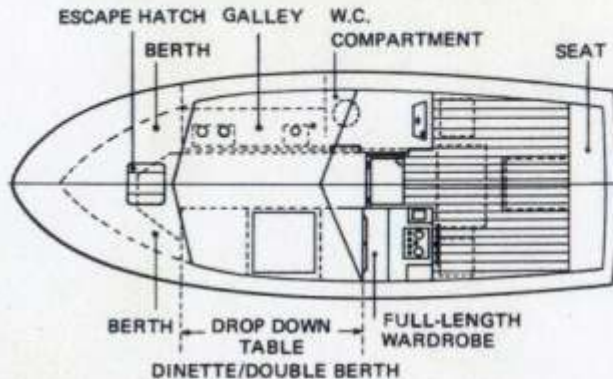
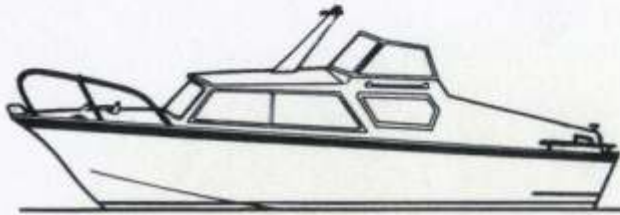

What can you expect from a 23 ft powercruiser? Step aboard the 700 Family Cruiser and have a pleasant surprise.

Fantastic comfort and careful design is packed into this beautifully styled craft.

Below deck, a luxury four-seat, upholstered dinette, with a laminate-faced dining-table, converting to a full-sized double berth. Forward, two foam upholstered single berths.

An attractive laminate-faced easy-clean galley unit is fitted to starboard. With stainless steel sink, two-burner cooker and ample stowage space behind sliding door units.

A luxury toilet compartment with full-sized sea toilet and hand basin vanity unit with mirror. A practical touch of luxury is added by the full-length wardrobe to port and moulded stowage bins throughout this light and spacious interior.

A family-sized self-draining cockpit with deep padded helmsman's seat is complemented by the cushioned stern bench and matching trim panels.

Specification

Overall length 693.4 cm (22' 9")
 Beam 259 cm (8' 6")
 Draft 83.8 cm (2' 9")

Fuel capacity approx. 209 litres (46 gal.)
 Water capacity approx. 90 litres (20 gal.)
 Approx. range 240 km (150 miles)
 Weight from 2,041 kg (4,500 lb)
 Overall height 243 cm (8' 0")
 Speeds up to 48 KMPH (35 MPH) according to engine installation.

Standard Equipment

Four berths.
 Separate toilet compartment with wash basin, vanity unit, mirror and freshwater pump.
 Fully upholstered forward berths, four-seater dinette with large table, carpeted throughout.
 Full-length wardrobe with coat hooks.
 Luxury Wrighton galley unit with stainless steel sink, freshwater pump, two-burner cooker with grill and storage compartments below.
 Sliding cabin windows.
 Safety escape hatch in foredeck.
 Safety-styled step-aboard pulpit and aft rail.
 Self-draining cockpit.
 Fully upholstered side-fixing helmsman's seat.
 Full navigation lights.
 Hawse pipe, anchor chocks, anchor chain and warp.
 Rubber rubbing strake.
 Stemhead fitting and secure foredeck mooring bollard.
 Stern quarter mooring bollards.
 Foredeck fairleads.
 Jackstaff and pulpit.
 Removable mast with waterproof socket.
 Calor gas box regulator and piping.
 Morse Teleflex steering and Morse engine controls.
 Fluorescent interior lights with copper angled reading lamps.
 Electric bilge pump.
 Electric horn.
 Engine room extractor fan, spark proofed.
 Fuel gauge.
 Heavy-duty 12v battery.
 Antifouling treatment to hull.

Engines

A comprehensive range of Volvo Penta, high-performance engines 115/100, 130/270, 170/270 and AQd21/270 Volvo Penta diesel.

Top right: Cockpit

Centre right: Saloon and Dinette

Bottom right: Toilet Compartment—Forward Bunks and Galley

*Far right: 700 Family Cruiser at Speed
 Over page: 700 Family Cruiser*





www.jonesboatyard.co.uk



850 FAMILY CRUISER

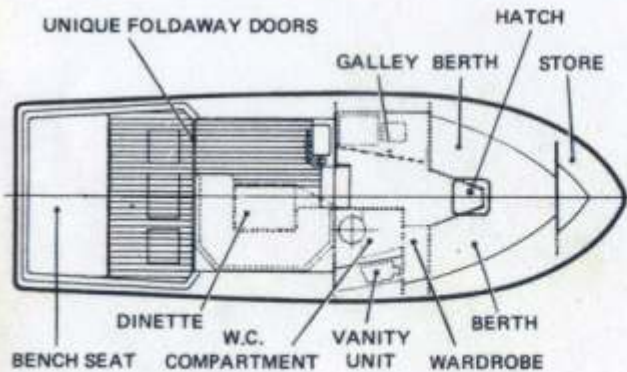
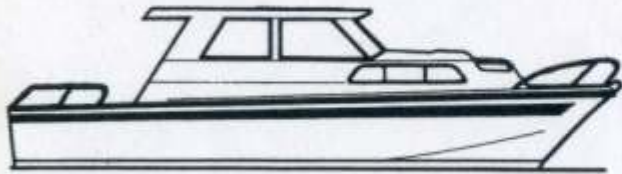

A success story in every respect. One of the most sought after 28 ft power cruisers ever produced. The accent is on spacious design, safety, tough construction, sea worthiness and good handling qualities.

It's a boat for all seasons scorning the worst of the weather, behind warm cabin doors or welcoming the sun from a foredeck sun seat and open cockpit. A commanding control position with a really panoramic view, responsive steering, Morse engine controls and a luxury instrument panel.

A spacious L-shaped dinette in the wheelhouse/saloon with portable table which can also be mounted in the cockpit in front of a deep upholstered sunseat for those wonderful good days. A single bunk, above the dinette settee which converts to a big double berth and two full-length berths in the forecabin.

Amidships, a laminate faced, styled galley unit, with stainless steel sink, two-burner cooker and grill and stacks of storage space with sliding polyester-faced doors.

To starboard, a luxury sea toilet compartment with full-width vanity unit and hand basin.

On deck, a stainless steel step-aboard pulpit with design-matched aft rail and more stainless steel fittings for strength and easy care. A useful foredeck sunseat with foam cushions and new improved cockpit with deeper, safer, self draining.

Add a wide range of performance plus inboard outdrive power units and you have speeds from seven to twenty knots, to take you away from those weekend cares.

Specification

Overall length 848 cm (27' 10")

Beam 285 cm (9' 4")

Draft 78 cm (2' 7")

Top right: Saloon
Centre right: Galley
Bottom right: Stern seat

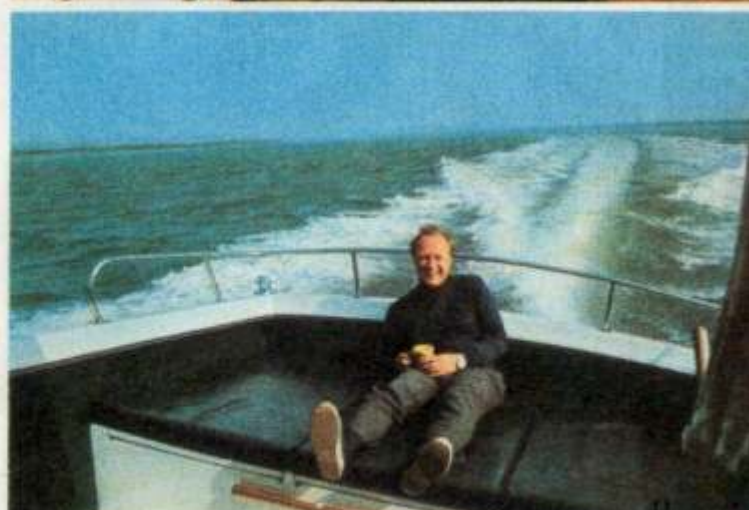

continued



Fuel capacity approx. 209 litres or 418 litres (46 or 92 gal.)

Water capacity approx. 209 litres (46 gals)

Approx. range 240/402 km (150/200 miles).

Dependent on power installation.

Approx. weight 3,175 kg (7,000 lb). Dependent upon specification.

Overall height 269 cm (8' 10")

Standard Equipment

Five berths.

Separate toilet compartment with wash basin, vanity unit, mirror and freshwater pump.

Wrighton luxury galley unit with stainless steel sink, freshwater pump.

Two-burner cooker with grill, and sliding doors.

Pedestal table, fitted carpet and full-length wardrobe with luxury Marley door partition to forecabin.

'L'-shaped dinette with double berth and single folding berth in saloon.

Storage below and side lockers.

Foredeck sunseat and aft cockpit seat, deep upholstered.

Sliding cabin windows throughout.

Fluorescent cabin lights and copper angled reading-lamps.

Full navigation lights, removable mast with water-proof socket.

Self-draining cockpit.

Hawse pipe, anchor chocks, anchor, chain and warp.

Safety-styled step-aboard pulpit and aft rail.

Rubber rubbing strake.

Foredeck fairleads.

Stern quarter mooring bollards.

Jackstaff and socket.

Engine room extractor fan, spark proofed.

Calor gas regulator and piping in vented compartment.

Large electric bilge pumps.

Electric horn.

Windscreen wiper on port side.

Heavy-duty 12v battery.

Teleflex/Morse steering, Morse engine controls.

Fuel gauge.

Antifoul treatment to hull.

Engines

A comprehensive range of Volvo Penta, high-performance engines 115/100, 130/270, 170/270 and AQd21/270, AQd32/270 Volvo Penta diesel.

Left: 850 Family Cruiser

Top right: Saloon—Dinette and forward cabin

Bottom right: Helm position

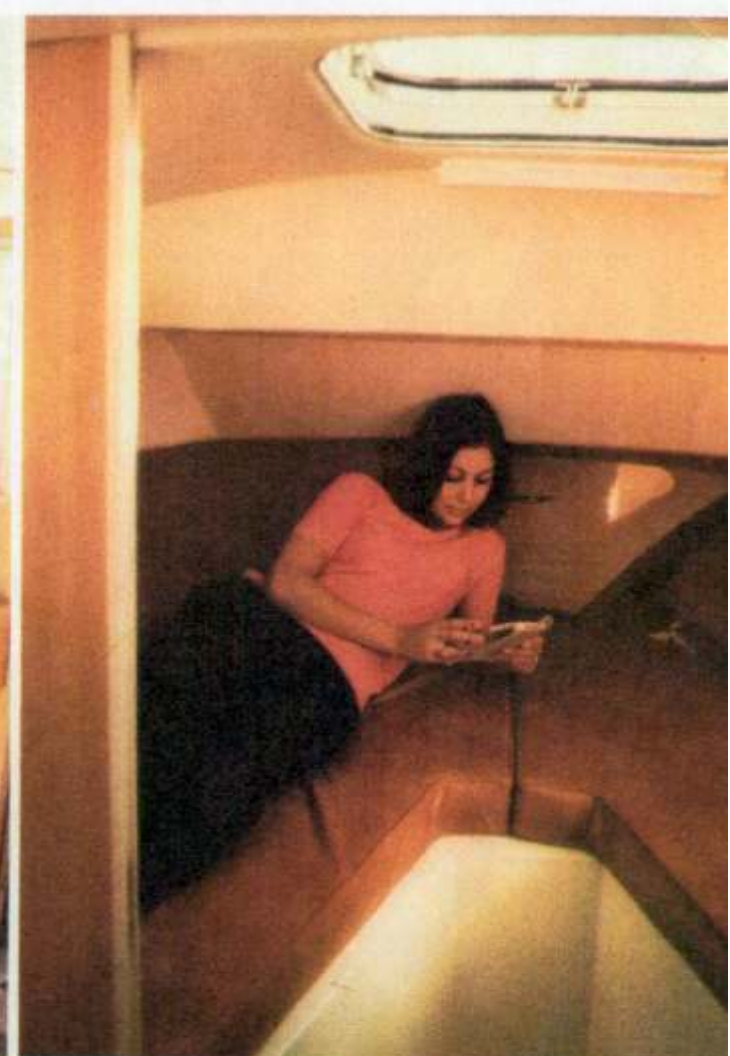

850 INTERNATIONAL

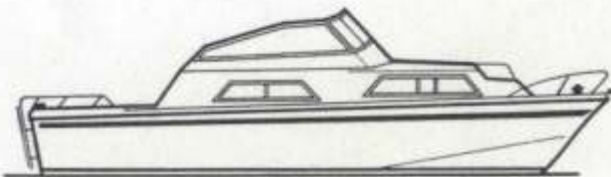

When we decided to build the 'International' we had just one aim in mind, and that was to achieve 'perfection'.

From the very start—as a member of the successful Cleopatra Range—she had an illustrious name to uphold. We wanted to go one better and by top original styling, make something extra special in the world of family cruisers.

We gathered together past customer requests and specifications, studied them intently and added our own thoughts. Then, when we were confident that every area had been explored, we set to work on the design itself.

In all it took us a year to complete—but the end result was well worth it.

The 850 International is a boat of sheer delight—incorporating more features than you'd expect from just one craft. The essence of quality and precision... representing craftsmanship at its very best.

From stem to spacious stern, in manoeuvrability, stability and construction she's designed to meet the highest standards of safety.

In the roughest seas she can be relied upon to handle well.

The sleek 'flying bridge', ample cockpit and large luxury interior make for a craft of breeding and flair. Designed for family pleasure and packed with seagoing potential.

Here is a craft of family appeal. The saloon with a luxurious double berth dinette to starboard, to port a single settee berth with laminate-faced unit and built-in refrigerator. Amidships, a beautifully equipped galley unit with stainless steel sink, two-burner cooker with grill and sliding door storage units above and below.

On the starboard side a well-designed full-sized sea toilet compartment with luxury vanity unit and hand basin.

In the forward cabin two full-length upholstered single berths with a folding Marley cabin door. A step-aboard stainless steel pulpit, stainless steel luxury aft rail with built-in stern bathing-ladder and stainless steel flying bridge rail, ladder and fittings complete the picture.

Specification

Overall length 848 cm (27' 10")

Beam 285 cm (9' 4")

Draft 78 cm (2' 7")

Fuel capacity approx. 209 litres or 418 litres (46 gal. or 92 gal.)

Water capacity approx. 209 litres (46 gal.)

Approx. range 240/402 km (150/200 miles)

Dependent on power installation.

Approx. weight 3,175 kg (7,000 lb). Dependent upon specification.

Overall height 269 cm (8' 10")

Standard Equipment

Two-berth dinette with single berth to port and sliding window units.

Two single berths in forecabin with luxury Marley door.

Fitted upholstery.

Fitted carpet throughout.

Independent cabin lighting with copper reading-lights.

Full-length wardrobe.

Built-in refrigerator.

Wrighton laminated faced galley unit with sliding doors.

Stainless steel sink.

Two-burner cooker with grill.

Fresh water pump.

Sea toilet and vanity unit with wash basin, mirror and fresh water pump, in separate compartment.

Sparkproofed engine extractor fan.

Calor gas regulator and piping in vented compartment.

Heavy-duty 12v battery(s).

Electric bilge pumps (2 large).

Electric horn, electric windscreen wiper.

Safety-styled step-aboard pulpit with stainless steel aft rail and extending bathing-ladder.

Stemhead fitting, mooring bollards, and foredeck fairleads.

Rubber rubbing strake.

Anchor chain and warp, hawse pipe and anchor chocks.

Jackstaff and socket.

Upholstered sunseat.

Morse Teleflex steering and Morse engine controls.



www.jonesboatyard.co.uk

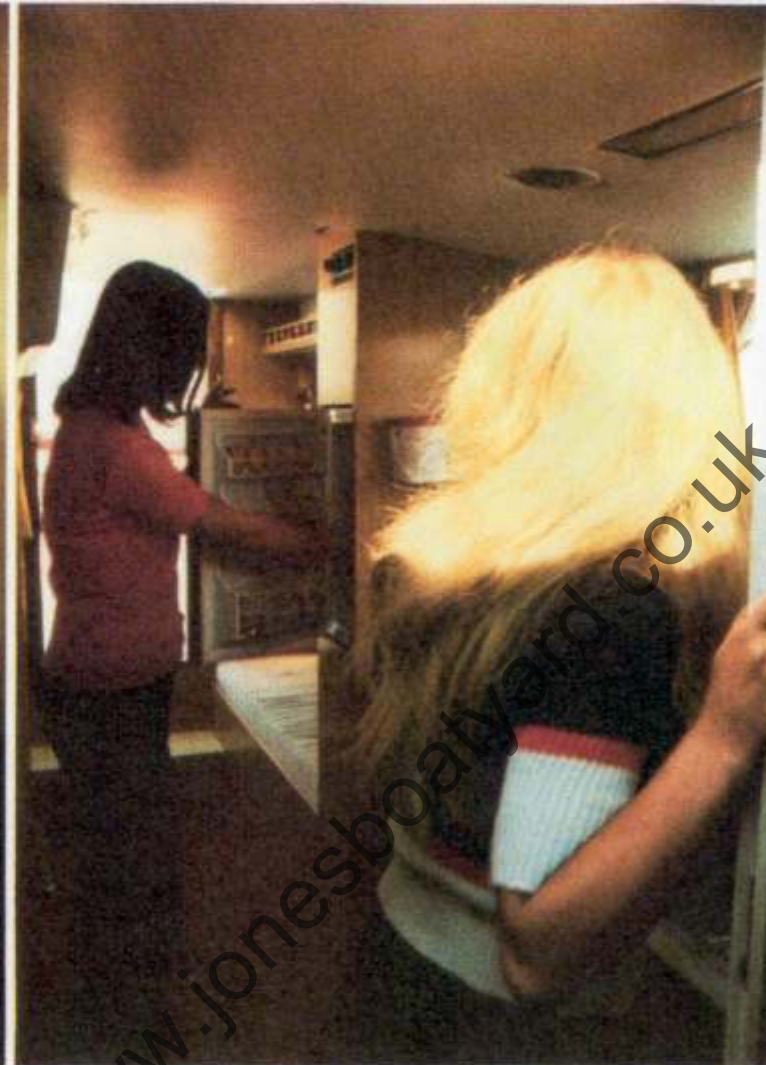

Fuel gauge.
Full navigation lights, removable mast with water-proof socket.
Antifouling treatment to hull.

Engines

A comprehensive range of Volvo Penta, high-performance engines 115/100, 130/270, 170/270 and AQd21/270, AQd32/270 Volvo Penta diesel.

Page 3: 850 International

Left: 850 International

Above left: Galley

Above centre: Refrigerator

Above right: Toilet compartment with vanity unit

Bottom right: Flying Bridge

Far right: Cockpit with stern seat



850 SPORTSRIDER

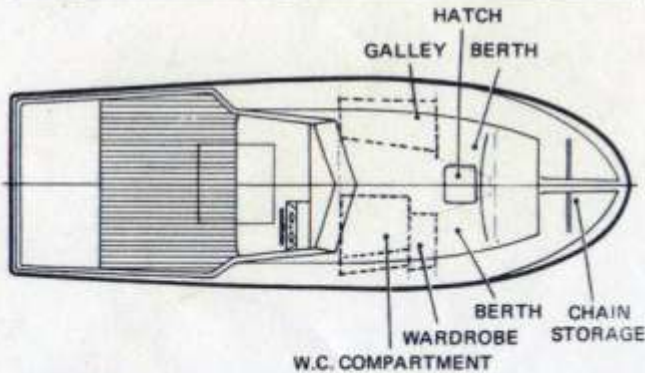
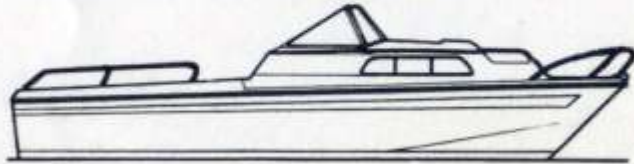

A thoroughbred from a good stable. Purr gently through the moorings to the end of that eight-knot limit, open up the twin throttles and unleash power. In a very few seconds you can be travelling at 35 knots and having the thrill of a lifetime.

We do sell single diesel engine versions to cruise you delightfully at seven or eight knots, along river or canal, but this is the boat to spoil yourself with. Fit two really powerful petrol inboard outdrive engines and go places. It won't cost you a fortune, but we can promise you'll feel like a millionaire behind the wheel of this impressive power cruiser.

Just stand back and look at the 850 Sportsrider, a rakish silhouette and sleek lines, a huge cockpit and a deep upholstered stern sunseat. Easy-to-handle throttle controls and a 'big ship' chrome steering wheel. An upholstered helmsman seat facing the moulded instrument console. All GRP, of course, like the rest of the craft. Easy to clean, trouble-free and no maintenance apart from the occasional polish.

On deck stainless steel pulpit, deck fittings and aft rail. Fully upholstered aft seat, colour-keyed trim panels and forward sunseat with deep foam cushions.

Below deck a luxury galley unit with stainless steel sink, two-burner cooker and grill and sliding door storage units above and below. A separate sea toilet compartment with a beautifully designed vanity unit, and wash basin. Two fully upholstered single settee berths with a Marley folding cabin door. The whole, fully carpeted and colour matched throughout.

Specification

Overall length 848 cm (27' 10")

Beam 285 cm (9' 4")

Draft 78 cm (2' 7")

Fuel capacity approx. 209 litres or 418 litres (46 or 92 gal.)

Water capacity approx. 209 litres (46 gal.)

Approx. range 240/402 km (150/200 miles).

Dependent on power installation.

Approx. weight 3,175 kg (7,000 lb). Dependent upon specification.

Overall height 269 cm (8' 10")

Standard Equipment

Two single berths in forecabin with fitted upholstery. Independent cabin lights with copper reading-lamps. Fitted carpet and luxury Marley door.

Sea toilet, vanity unit, wash basin with freshwater pump and mirror in separate compartment.

Full-length wardrobe.

Wrighton laminated faced galley unit with sliding doors.

Stainless steel sink.

Two-burner cooker with grill.

Freshwater pump.

Safety-styled step-boards, pulpit and aft rail.

Stemhead fitting and foredeck mooring bollard.

Stern quarter bollards.

Rubber rubbing strakes.

Upholstered foredeck sunseat.

Sliding window units.

Self-draining cockpit and deep aft sunseat.

Electric bilge pumps (2 large).

Electric horn and electric windscreen wiper.

Heavy duty 12v battery(s).

Cabin gas regulator and piping.

Throttle/Morse steering and Morse engine controls.

Fuel gauge.

Full navigation lights, removable mast and waterproof socket.

Jackstaff and socket.

Antifouling treatment to hull.

Anchor, chain and warp, hawse pipe and anchor chocks.

Engines

A comprehensive range of Volvo Penta, high-performance engines 115/100, 130/270, 170/270 and AQd21/270, AQd32/270 Volvo Penta diesel.

*Right and far right: 850 Sportsrider at Speed
Bottom right: Cockpit and companion way*





www.jonesboatyard.co.uk

ENGINES

AQ 115A/100

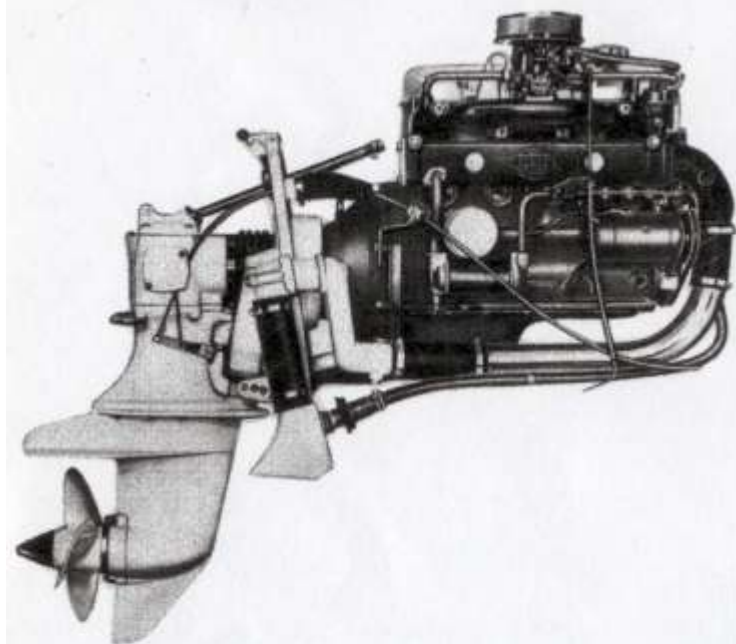

DATA

Type of operation	Four-stroke carburettor engine with overhead valves
Type designation	AQ 115A/100
Max. output (SAE)	115 h.p.
Max. operating speed, r.p.m.	5100
Number of cylinders	4 in line
Capacity, litres(cu.in.)	1.979(121)
Bore/stroke, mm(in.)	88.9/80(3.50/3.15)
Compression ratio	9.5:1
Outboard drive, type designation/ratio	100/1.66:1
Total weight, kg(lb.), approx	210(460)

AQ 130/270 D

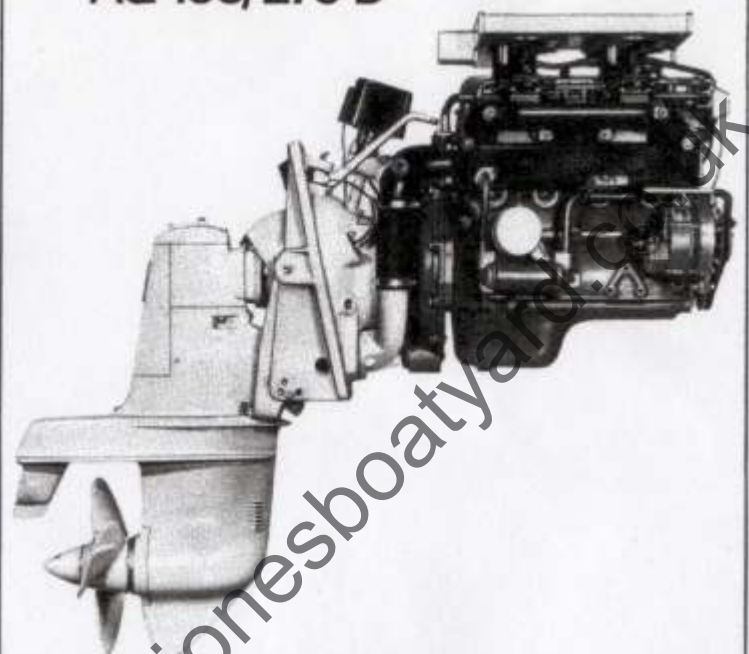

DATA

Type of operation	Four-stroke carburettor engine with overhead valves
Type designation	AQ 130C/270D
Max. output (SAE)	130 h.p.
Max. operating speed, r.p.m.	5100
Number of cylinders	4 in line
Capacity, litres(cu.in.)	1.986(121)
Bore/stroke, mm(in.)	88.9/80(3.50/3.15)
Compression ratio*	9.5:1
Outboard drive, type designation/ratio	270D/2.15:1
Total weight, kg(lb.), approx	230(510)

AQ 170/270 C

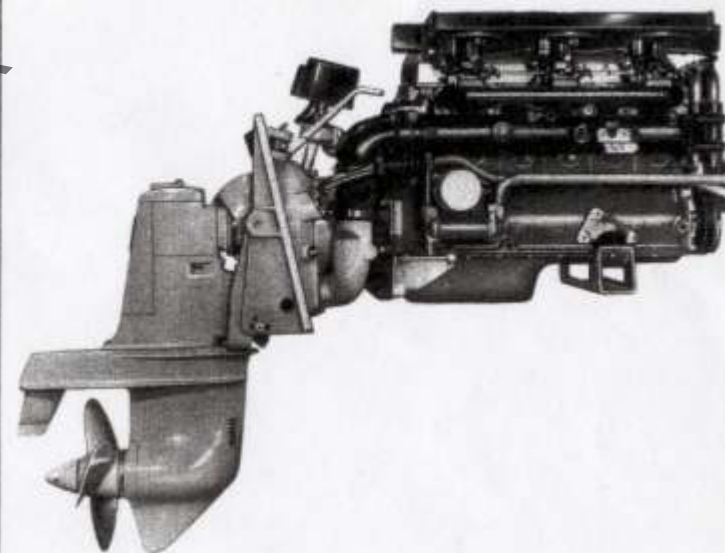

DATA

Type of operation	Four-stroke carburettor engine with overhead valves
Type designation	AQ 170A/270C
Max. output (SAE)	170 h.p.
Max. operating speed, r.p.m.	5000
Number of cylinders	6 in line
Capacity, litres(cu.in.)	2.979(182)
Bore/stroke, mm(in.)	88.9/80(3.50/3.15)
Compression ratio	9.5:1
Outboard drive, type designation/ratio	270C/1.89:1
Total weight, kg(lb.), approx	280(615)

www.jonesboatyard.com

AQD 21/270 D

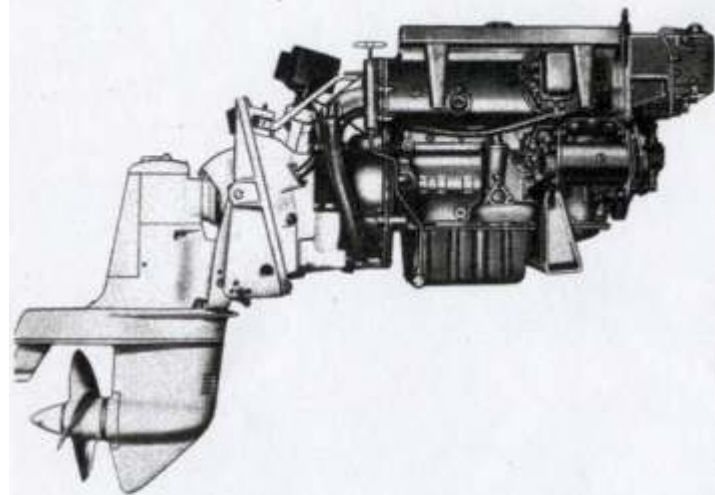

DATA

Type of operation Four-stroke Diesel engine with swirl chambers
 Type designation AQ D21A/270D
 Max. output, pleasure boats (SAE) 75 h.p.*
 Max. operating speed, r.p.m. 4500
 Number of cylinders 4 in line
 Capacity c.c.(cu.in.) 2112(129)
 Bore/stroke, mm(in.) 90/83(3.54/3.27)
 Valves Overhead
 Outboard drive, type designation/ratio 270D/2.15:1
 Total weight, kg(lb.), approx 300(660)
 * Max. output only permitted for short periods of time
 Cruising speed is 200 r.p.m. lower than maximum engine speed.

AQD 32/270 D

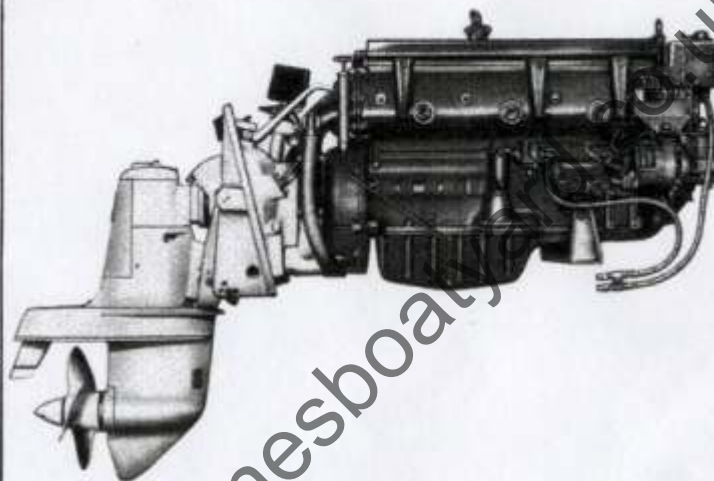

DATA

Type of operation Four-stroke Diesel engine with swirl chambers
 Type designation AQ D32A/270D
 Max. output, pleasure boats (SAE) 106 h.p.*
 Max. operating speed, r.p.m. 4000
 Number of cylinders 6 in line
 Capacity, litres(cu.in.) 3.17(193)
 Bore/stroke, mm(in.) 90/83(3.54/3.27)
 Valves Overhead
 Outboard drive, type designation/ratio 270D/2.15:1
 Total weight, kg(lb.), approx 355(785)
 * Max. output only permitted for short periods of time
 Cruising speed is 200 r.p.m. lower than maximum engine speed.

VOLVO Single installations ●

Twin installations ●●

Petrol

AQ 115/100 AQ 130/270 AQ 170/270

700 Weekender	● ●●	● ●●	● ●●
700 Sports Fisherman	● ●●	● ●●	●
700 Family Cruiser	● ●●	● ●●	●
850 Fast Family Cruiser	● ●●	● ●●	●●
850 Sportsrider	● ●●	● ●●	●●
850 International	● ●●	● ●●	● ●●

Diesel

AQ D21/270 AQ D32/270

700 Weekender	● ●●		
700 Sports Fisherman	●		
700 Family Cruiser	●		
850 Fast Family Cruiser	● ●●	●●	
850 Sportsrider	● ●●		
850 International	● ●●	●●	

Years of research have developed a programme of hard-thought-out and well-designed craft constructed by top craftsmen using the finest materials and the newest techniques. This programme must be matched by the finest available power units. Built by the leaders in their field . . .





www.jonesboatyard.co.uk